

Extruded Aluminum Louver • 4" Deep • Drainable Baffle Blades • Adjustable • Concealed Actuator

STANDARD CONSTRUCTION

FRAME: .081" thk. (nominal) extruded aluminum, 6063-T52/T6 alloy. Channel type.

BLADE: .081" thk. (nominal) extruded aluminum 6063-T52/T6 alloy. Blades are approximately 4" on centers.

LOUVER FACE: Full width sill with drain head and non-drain blades contained within drain jambs.

SHAFT: .50" dia aluminum "Pin-Lock" rod.

BEARINGS: Celcon bearing material so that there will be no metal to metal friction.

LINKAGE: Extruded aluminum, concealed in the channel out of the airstream. The pivots, which rotate in Celcon bearings, are .50" dia. plated and machined steel. The pivot is locked to the 5/16" dia. aluminum linkage rod by a 1/4 - 20 set screw with epoxy locking patch.

SEALS: Extruded silicone rubber seals at blade edge. Polyurethane at jambs.

SCREEN: (When indicated, in a removable frame)
1/2" flattened aluminum, .051" thk.,

- or- 1/2" sq. mesh intermediate double crimped aluminum wire, .063" dia.,
- or- 1/8" aluminum mesh insect screen, .011" dia.

FINISH: Mill.

ACTUATOR: 120 VAC spring return normally closed.
133 in-lbs. torque.

OPTIONS

Finishes - Enamels, Epoxies, etc.
Other screens also available.

NOTES

1. Nominal deductions will be made to the opening size given.
2. Approximate shipping weight is 5.0 lbs./sq.ft.

LOUVER SIZES

Min Panel	Max Single Panel
12"W x 19"H	48"W x 96"H

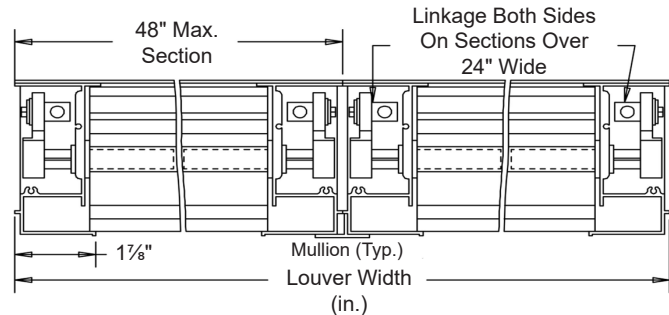
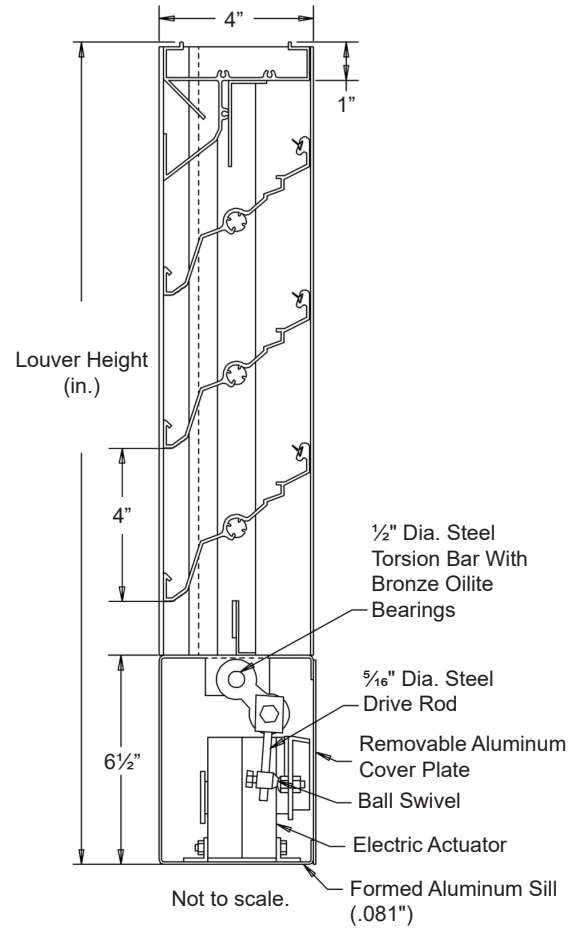

Item #	Qty	Width	Height	Width	Height	Mullion	Type	Location	Union Made
		Opening Size		Louver Size			Screens		
Arch. / Eng. :						EDR:		ECN:	Job:
Contractor:									
Project:						Date:		DWN:	DWG:

In the interest of product development, Louvers & Dampers reserves the right to make changes without notice.

www.louvers-dampers.com

450 Riverside Drive • Wyalusing PA, 18853 • Phone 570-746-1888 • Fax 570-746-9286

